

Ford



Go Further

Leader

Key exterior features

- Door mirrors with blind spot eliminator and integrated side indicator
- Remote central door locking
- Passenger's side sliding load door
- Halogen Projector Headlights with courtesy delay
- Rear mudflaps
- 15" steel wheels with half caps on 290 and 310 series
- 16" steel wheels with half caps on 330 and 350 series, and all models with automatic transmission

Key interior features

- DAB/AM/FM radio with 2 x USB, 4.2" Monochrome TFT Screen (non touch), Bluetooth, Emergency Assistance, Ford Pass Connect (embedded modem) (two woofers and two tweeters), remote audio controls and USB connectivity port with iPod® functionality
- Height- and reach-adjustable steering column
- Trip computer
- Electrically-operated front windows
- Driver's airbag
- 4-way adjustable driver's seat with cushion tilt and armrest
- Easy-clean rubber floor covering in cab
- Complete rubber floor covering (Double Cab-in-Van only)
- Full-width DIN/ISO-compliant unglazed metal bulkhead (Van only)
- Unique design glazed bulkhead (Double Cab-in-Van only)
- DIN 75410 compliant tie-down loops



Engines

Diesel

- 105 PS (77 kW)/310 Nm
- 130 PS (96 kW)/360 Nm
- 170 PS (125 kW)/390 Nm
- 130 PS (96 kW)/360 Nm EcoBlue Hybrid

Bodystyles

- Van
- Double Cab-in-Van

Model shown is a Transit Leader L3 H2 Van in Moondust Silver metallic body colour (option).

Trend

Key exterior features additional to Leader

- Power-foldable door mirrors
- Projector-style halogen headlights with static cornering lights
- Front fog lights
- Full wheel covers
- Front and rear parking distance sensors
- Rain-sensing front wipers

Key interior features additional to Leader

- AM/FM Radio with DAB, Ford SYNC 2.5 (includes Emergency Assistance*) with Bluetooth®, voice pass-through, AppLink®, audible text messaging and privacy mode, 8" touchscreen display, extended integrated control panel, USB connectivity port with iPod® functionality, remote audio controls, four speakers (two woofers and two tweeters)
- Easy to Clean Load Floor (Van only)
- Cruise control with Adjustable Speed Limiter
- Driver's seat lumbar adjust
- Quickclear heated windscreen
- Leather-trimmed steering wheel
- Instrument panel dimmer
- Lockable glovebox
- Map reading lights
- Washer fluid low-level sensor
- Complete load compartment Shoulder height trim board (Van only)



Engines

Diesel

130 PS (96 kW)/360 Nm

170 PS (125 kW)/390 Nm

130 PS (96 kW)/360 Nm EcoBlue Hybrid

Bodystyles

Van

Double Cab-in-Van

*Ford Emergency Assistance is an innovative SYNC feature that uses a Bluetooth®-paired and connected mobile phone to help vehicle occupants initiate a call to the local Communications Centre, following a vehicle crash event involving an airbag deployment or fuel pump shut off. The feature operates in more than 40 European countries and regions.

Model shown is a Transit Trend L3 H2 Van in Kapoor Red metallic body colour (option).

Limited

Key exterior features additional to Trend

- Bi-xenon headlights with LED daytime running lights
- 16" 5x2-spoke alloy wheels
- Body Colour Front Bumper
- Locking wheel nuts
- Side Park Assist

Key interior features additional to Trend

- Manual front air conditioning
- AM/FM Radio with DAB, Ford SYNC 2.5 (includes Emergency Assistance*) with Bluetooth®, voice pass-through, AppLink®, audible text messaging and privacy mode, 8" touchscreen display, extended integrated control panel, USB connectivity port with iPod® functionality, remote audio controls, four speakers (two woofers and two tweeters)
- Leather-trimmed gearshift knob



Engines

Diesel

- 130 PS (96 kW)/360 Nm
- 170 PS (125 kW)/390 Nm
- 185 PS (138 kW)/415 Nm
- 130 PS (96 kW)/360 Nm EcoBlue Hybrid

Bodystyles

- Van
- Double Cab-in-Van

*Ford Emergency Assistance is an innovative SYNC feature that uses a Bluetooth®-paired and connected mobile phone to help vehicle occupants initiate a call to the local Communications Centre, following a vehicle crash event involving an airbag deployment or fuel pump shut off. The feature operates in more than 40 European countries and regions.

Model shown is a Transit Limited L3 H2 Van in Chrome Blue metallic body colour (option).

Dimensions (mm)

	L2 H2 Van		L2 H3 Van		L3 H2 Van		L3 H3 Van		L4 H3 Van
	FWD	RWD/ AWD	FWD	RWD/ AWD	FWD	RWD/ AWD	FWD	RWD/ AWD	RWD/ AWD
A Overall length	5531	5531	5531	5531	5981	5981	5981	5981	6704
B Overall width with mirrors	2474	2474	2474	2474	2474	2474	2474	2474	2474
Overall width with folded back mirrors	2112	2112	2112	2112	2112	2112	2112	2112	2112
Overall width without mirrors (SRW)	2059	2059	2059	2059	2059	2059	2059	2059	2059
Overall width without mirrors (DRW)	-	-	-	-	-	-	-	-	2126
C Overall height*	2413- 2533	2447- 2534	2652- 2769	2686- 2771	2411- 2530	2443- 2533	2676- 2767	2682- 2769	2715- 2778
D Wheelbase	3300	3300	3300	3300	3750	3750	3750	3750	3750
E Front of vehicle to front wheel centre	1023	1023	1023	1023	1023	1023	1023	1023	1023
F Rear of vehicle to rear wheel centre	1208	1208	1208	1208	1208	1208	1208	1208	1931
G Side door entry width	1300	1300	1300	1300	1300	1300	1300	1300	1300
H Side load door entry height	1700	1600	1700	1600	1700	1600	1700	1600	1600
I Rear door entry width	1565	1565	1565	1565	1565	1565	1565	1565	1565
J Rear door entry height	1748	1648	1987	1887	1748	1648	1987	1887	1887
K Maximum loadspace length (at floor with bulkhead)	3044	3044	3044	3044	3494	3494	3494	3494	4217
L Maximum loadspace width	1784	1784	1784	1784	1784	1784	1784	1784	1784
M Loadspace between wheel arches (SRW)	1392	1392	1392	1392	1392	1392	1392	1392	1392
Loadspace between wheel arches (DRW)	-	-	-	-	-	-	-	-	1154
N Load floor to roof	1886	1786	2125	2025	1886	1786	2125	2025	2025
O Loading height*	482- 605	615- 706	482- 602	615- 703	478- 592	608- 695	478- 590	609- 692	608- 677
P Maximum load volume (with bulkhead) (cu.m)	10.0	9.5	11.2	10.7	11.5	11.0	13.0	12.4	15.1
Loadspace (with bulkhead) (VDA) (cu.m)	9.3	8.8	10.3	9.9	10.8	10.2	12.0	11.5	14.1

L2 = Medium wheelbase, **L3** = Long wheelbase, **L4** = Long wheelbase extended length. **H2** = Medium Roof, **H3** = High Roof, **FWD** = Front-wheel drive, **RWD** = Rear-wheel drive, **AWD** = All-wheel drive, **SRW** = Single rear wheels, **DRW** = Dual rear wheels. All dimensions (shown in mm) are subject to manufacturing tolerances and refer to minimum specification models and do not include additional equipment. *Height dimensions show the range from minimum to maximum of a fully laden, lowest payload vehicle to unladen highest payload vehicle. These illustrations are for guidance only. **VDA method** This is the method used by the Verband der Automobilindustrie (VDA) in Germany. A VDA figure is determined by filling the loadspace with 'litre' blocks, each measuring 200x100x50 mm. The blocks are then counted, and the numerical result is converted into cubic metres.

Van



L2 H2

L3 H2



L2 H3

L3 H3

L4 H3

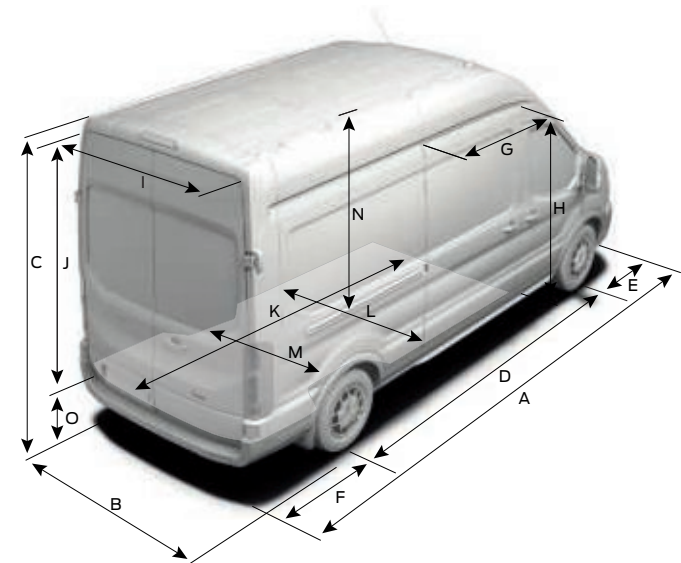

Weights and loads

	Max. gross payload (excluding driver) (kg)	Gross vehicle mass (kg)	Min. kerb mass (excluding driver) (kg)	Front axle plated mass (kg)	Rear axle plated mass (kg)
Van (3 seats)					
FWD					
290 L2 H2	895-936	2940	2004-2046	1625	1575
310 L2 H2	1043-1136	3140	2004-2098	1650	1725
310 L2 H3	1001-1094	3140	2046-2139	1650	1725
310 L3 H2	1038-1082	3140	2058-2102	1750	1725
310 L3 H3	993-1038	3140	2102-2147	1750	1725
330 L2 H2	1337	3365	2028	1750	2050
330 L2 H3	1295	3365	2070	1750	2050
330 L3 H2	1284	3365	2081	1750	2050
330 L3 H3	1239	3365	2126	1750	2050
350 L2 H2	1379-1472	3500	2028-2121	1750	2150
350 L2 H3	1337-1430	3500	2070-2163	1750	2150
350 L3 H2	1322-1419	3500	2081-2178	1750	2250
350 L3 H3	1277-1374	3500	2126-2223	1750	2250
RWD					
350 L2 H2	1319-1385	3500	2115-2181	1750/1850	2150
350 L2 H3	1277-1342	3500	2158-2223	1750/1850	2150
350 L3 H2	1263-1332	3500	2168-2237	1750/1850	2250
350 L3 H3	1218-1286	3500	2214-2282	1750/1850	2250
350 L4 H3	1110-1176	3500	2324-2390	1750/1850	2250/2450**
470 L4 H3	2209	4700	2491	1850	3300
AWD					
350 L2 H2	1279	3500	2221	1850	2150
350 L2 H3	1237	3500	2263	1850	2150
350 L3 H2	1217	3500	2283	1850	2250
350 L3 H3	1172	3500	2328	1850	2250

FWD = Front-wheel drive, **RWD** = Rear-wheel drive, **AWD** = All-wheel drive, **L2** = Medium wheelbase, **L3** = Long wheelbase, **L4** = Long wheelbase extended length, **H2** = Medium Roof, **H3** = High Roof. Figures apply to Medium Roof vehicles unless otherwise stated. For High Roof option vehicles, kerb mass is increased and payload reduced. Kerb mass is affected by many factors such as bodystyles, engines and options. It is the weight of a standard-specification base series vehicle (different series will have different kerb masses), including fluids and fuel tank 90% full, but without the driver (75 kg), crew or cargo. Payload within this guide is the difference between gross vehicle mass (GVM) and kerb mass with a further 75 kg deduction for the weight of the driver. It must be noted that actual weight will always be subject to manufacturing tolerances which may result in payload variations between this guide and actual weight. For customers intending to load vehicle close to maximum payload, we suggest you also add a margin for error of 5% of kerb mass to the kerb mass figure before calculation, to reduce risk of overloading. NB: It is the responsibility of the vehicle operator to ensure their vehicles are legally compliant for road use. Consult your Ford Commercial Vehicle Dealer for more information.

Driving experience

	Leader	Trend	Limited
Driver assistance			
Cruise control (including leather-trimmed steering wheel and Adjustable Speed Limiter)	○/□	●	●
Blind Spot Information System with Cross Traffic Alert (includes trailer tow functionality if specified with trailer tow attachments, and power-foldable, electrically-operated and heated door mirrors)	○	○	○
Lane-Keeping Alert ²⁾ (includes auto high beam, high-series instrument cluster, Quickclear heated windscreen and automatic headlights) (standard on 350HD and 470 models)	○/□	○/□	○/□
Lane-Keeping Aid ²⁾ (includes Lane-Keeping Alert)	○/□	○/□	○/□
Adaptive Cruise Control (ACC) (includes Pre-Collision Assist ²⁾ (with Pedestrian Protection), leather-trimmed steering wheel and Lane-Keeping Alert ²⁾	○	○	○
Intelligent Adaptive Cruise Control (includes Pre-Collision Assist ²⁾ and leather-trimmed steering wheel) (only available when specified with ICE Pack 25)	□	□	□
Acceleration control			
Rear-view camera (includes centre high-mounted LED downlighting, front and rear parking distance sensors and front fog lights)	○	○	○
Front wide-view camera with split-view (includes rear wide-view camera, centre high-mounted LED downlighting, front and rear parking distance sensors and front fog lights)	○	○	○
Parking distance sensor(s) – Front and rear (includes front fog lights)	○	●	●
Side Park Aid	□/○	□/○	●
Enhanced Active Park Assist – Includes perpendicular park assist, Park-Out Assist and Side Park Aid (not available on L4 470 variants and L4 350)	○	○	○
Speed Limiter – (56 mph) (standard on 470 L4 variants)	○/●	○/●	○
Speed Limiter – (62 mph) (not available on 470 L4 variants)	○	○	○
Speed Limiter – (70 mph) (not available on 470 L4 variants)	○	○	○
Trailer Sway Control (TSC) ¹⁾ (activated with Ford trailer tow attachments) (Not available on DCIV L4 350)	□	□	□
Exterior lighting			
Headlights – Halogen projector headlights containing daytime running lights	●	–	–
Headlights – Halogen projector headlights containing LED daytime running lights and static cornering	–	●	–
Headlights – Bi-xenon headlights with LED daytime running lights and static bending	○	○	●
Headlights – Levelling control	●	●	●
Headlights – Automatic on/off	□	●	●
Headlights – Courtesy delay, 30 seconds duration	●	●	●
LED Downlighter (also included within rear view camera)	○/□	○/□	○/□
Fog lights – Front	○/□	●	●
Roof marker lights (DRW models of Van only - 470 L4)	●	●	–
Suspension			
Front, independent MacPherson struts, variable rate coil springs, stabiliser bar, gas-pressurised shock absorbers and rear leaf springs	●	●	●
Instruments and controls			
Tyre Pressure Monitoring System (TPMS) ¹⁾ (Not available with Dual Rear Wheel)	○	○	○
Tachograph – Smart digital, electronic, 24-hour (manual transmission only)	○	○	○
Technology			
Selectable driving mode	●	●	●

● = Standard, ○ = Option, at extra cost, □ = Part of an option pack, at extra cost. ¹⁾Safety feature, ²⁾Driver assistance feature.

Performance and efficiency

	Leader	Trend	Limited
Instruments and controls			
Vehicle Maintenance Monitor driver information system	●	●	●
Trip computer (distance to empty, instant and average fuel consumption, average speed, outside temperature)	●	●	●
Programmable Interface Module	○	○	○
Battery – Cold start (-20°C)	●	●	●
Battery – Twin Improved Flooded (IF), cold start (-29°C)	○	○	○
Battery – Twin H8 AGM deep cycle battery (heavy-duty battery)	○	○	○
Alternator – Standard duty 165 Amp (standard only on AWD variants)	●	●	-
Alternator – Extra heavy-duty 250 Amp (standard only on FWD/RWD variants)	●	●	●
Technology			
Water in fuel filter with sensor	●	●	●

● = Standard, ○ = Option, at extra cost.

Comfort and convenience

	Leader	Trend	Limited
Interior convenience			
Assist handle – Located on B-pillar (Van only)	●	●	●
Bottle holder – Twin, 2-litre bottle capacity, fascia-mounted	●	●	●
Glovebox – With lid and A4 file storage capability	●	-	-
Glovebox – Lockable, with lid and A4 file storage capability	□	●	●
AUX 2-DIN instrument panel console	○	○	○
MyKey	●	●	●
Overhead console	●	●	●
Power point socket – 2 x 12 V (located on instrument panel and in stowage bin)	●	●	●
Power point socket – 230 V (400 W) power converter (not available on EcoBlue Hybrid models)	○	○	○
Power point socket – 12 V (located in rear)	○	○	○
Smokers' Pack – Cigar lighter and ash cup	○	○	○
Storage – Front door map pockets	●	●	●
Storage – Underseat stowage compartment (under dual passenger seat)	●	●	●
Audio and communication systems			
ICE Pack 17 – DAB/AM/FM Radio with SYNC with Bluetooth®, 4.2" TFT display, remote audio controls, integrated control panel, USB connectivity port with iPod® functionality, FordPass Connect modem, with four speakers (two woofers and two tweeters) (must be selected as a mandatory option on Leader unless ICE Pack 21, 24 or 25 is selected)	○	-	-
ICE Pack 21 – DAB/AM/FM Radio with SYNC 3 with Bluetooth®, Applink, audible text messaging and privacy mode, 8" touchscreen display, extended integrated control panel, FordPass Connect modem, two USB connectivity ports with iPod® functionality, remote audio controls, with six speakers (must be selected as a mandatory option on Trend unless ICE Pack 24 or 25 is selected)	○	○	●
ICE Pack 24 – DAB/AM/FM Radio navigation system with SYNC 3 with Bluetooth®, Applink, audible text messaging and privacy mode, 8" touchscreen display, extended integrated control panel, FordPass Connect modem, two USB connectivity ports with iPod® functionality, remote audio controls, with six speakers	○	○	○
ICE Pack 25 – DAB/AM/FM Radio navigation system with Intelligent Adaptive Cruise control, with SYNC 3 with Bluetooth®, Applink, audible text messaging and privacy mode, 8" touchscreen display, extended integrated control panel, FordPass Connect modem, two USB connectivity ports with iPod® functionality, remote audio controls, with six speakers	○	○	○

Comfort and convenience

	Leader	Trend	Limited
Climate control			
Air conditioning – Front, including filter-air pollen purifier	○	○	●
Heater – Positive Thermal Co-efficient (PTC)	●	●	●
Interior lighting			
Courtesy lights – Header-mounted, front with theatre dimming	●	–	–
Courtesy lights – Header-mounted, front with theatre dimming and map lights	–	●	●
Courtesy lights – Rear seat, with theatre dimming (Double Cab-in-Van only)	●	●	●
Loadspace compartment lights	●	●	●
LED loadspace compartment lights	○	○	○
Seating			
Driver's seat – 4 way (fore/aft; recline; height; and tilt) with armrest	●	●	●
Driver's seat – 4 way heated (fore/aft; recline; height; tilt; and lumbar) with armrest	–	○	○
Front passenger's seat – Single, 4 way (fore/aft; and recline)	○	○	○
Front passenger's seat – Single, 4 way heated (fore/aft; recline; height; and tilt)	○	○	○
Front passenger's seat – Dual, fixed back with split lift-up seat cushion for stowage, fold-out table	●	●	●
Front passenger's seat – Dual, heated (outer seat only), fixed back with split lift-up seat cushion for stowage, fold-out table	○	○	○
Double Cab-in-Van – Second row triple wide seats	●	●	●
Double Cab-in-Van – Second row quad seats (2+2) (L3 350 variant only)	○	○	○
Instruments and controls			
Hydraulic power-assisted steering (HPAS) (only available with AWD)	●	–	–
Electric power-assisted steering (EPAS) (not available with AWD)	●	●	●
Steering column – Rake- and reach-adjustable	●	●	●
Wipers – Front, variable/intermittent with electric wash	●	–	–
Wipers – Front, rain-sensing (includes automatic headlights)	□	●	●
Wipers – Rear with auto reverse wipe and electric wash (only available with glazed rear doors)	○	○	○
Steering wheel – 4-spoke, polyurethane	●	–	–
Steering wheel – 4-spoke, leather-trimmed	□	●	●
Gearshift knob – Leather-trimmed	–	–	●
Windows – Electrically-operated front with one-touch lowering on driver's side	●	●	●
Technology			
Fuel tank – 70 litres	●	●	●
Ford Easy Fuel capless refuelling system with misfuel inhibit	●	●	●
Standard fuelling system instead of Ford Easy Fuel capless refuelling system	○	○	○
AdBlue® aftertreatment system – 21 litre	●	●	●
Auto Start-Stop system	●	●	●
Quickclear heated windscreen	□	●	●

● = Standard, ○ = Option, at extra cost, □ = Part of an option pack, at extra cost.

Safety and security

	Leader	Trend	Limited
Safety			
Anti-lock braking system (ABS) with electronic brake-force distribution (EBD) ¹⁾	●	●	●
Electronic Stability Control (ESC) ¹⁾	●	●	●
Curve Control ¹⁾	●	●	●
Hill Start Assist (HSA) ²⁾	●	●	●
Load Adaptive Control (LAC) ¹⁾	●	●	●
Emergency Brake Assist (EBA) ¹⁾	●	●	●
Emergency Brake Warning ²⁾	●	●	●
Roll Stability Control (RSC) ¹⁾	●	●	●
Airbag – Driver's ¹⁾	●	●	●
Airbag – Front passenger's ¹⁾ (includes passenger's airbag deactivation function) (also available in some seat packs)	○/□	○/□	○/□
Airbag – Front side and curtain airbags ¹⁾	□	□	□
Seat belts – 3-point diagonal inertia reel (all seats) ¹⁾	●	●	●
ISOFIX child seat – 2 x second-row attachments ¹⁾ – (Double Cab-in-Van only)	●	●	●
First aid kit	○	○	○
Security			
Alarm – Perimeter	○	○	○
Alarm – Thatcham Category 1 (Van) – Cab interior sensing, inclination sensor and trailer coupling, when fitted (includes remote locking with 2 key fobs)	○	○	○
Immobiliser – Safeguard Passive Anti-Theft System (PATS) (insurance-approved Category 2 immobiliser)	●	●	●
Locks – Power central locking (in lieu of power deadlocks)	○	–	–
Locks – Power door deadlocks, shielded with strengthened mountings	●	●	●
Locks – Remote control central locking with 1 key fob	●	–	–
Locks – Remote control central locking with 2 key fobs	○	●	●
Locks – Configurable unlocking 2-stage unlocking*	●	●	●
Locks – Configurable unlocking independent driver's door unlocking*	○	–	–
Locks – Configurable unlocking (Van) courier unlocking with auto slam lock, zonal opposite door relocking and 3 second auto relocking*	○	–	–
Locks – Auto relocking, doors relock after 45 seconds if no door is opened	●	●	●
Locks – Audio mis-lock feedback, audible signal if a door is ajar when locking activated	●	●	●
Locks – Auto locking on drive-away, doors automatically lock at 5 mph	●	●	●
Locks – Key-operated bonnet release	●	●	●
Brakes			
Dual-circuit, with self-adjusting servo-assistance and ABS. Front and rear discs	●	●	●

● = Standard, ○ = Option, at extra cost, □ = Part of an option pack, at extra cost. ¹⁾Safety feature, ²⁾Driver assistance feature. *For details of the configurations available please consult your Ford Dealer. Please note: Configurable locking must be defined at the time of order, it cannot be ordered as a Dealer-fitted option or accessory. ***Note: A rear-facing child seat should never be placed in the front passenger seat when the Ford vehicle is equipped with an operational front passenger's airbag.**

Utility

	Leader	Trend	Limited
Body			
Doors – Passenger's side load (sliding) door	●	●	●
Dual Side Load Doors (not available on L4 Double Cab-in-Van)	○	○	○
Power step – Passenger's side load door (Van only, not available on FWD or AWD models)	○	○	○
Doors – Unglazed rear doors, hinged for 180° opening, positive stop at 90° (L2 and L3 models only)	●	●	●
Doors – Unglazed rear doors, hinged for widest opening up to magnetic door retainers (not available on L2 models, optional on L3 models and standard on L4)	○	○	○
Doors – Glazed and heated	○	○	○
Doors – Power slide side door with Close Assist (not available on Double Cab-in-Van or on L2 Van) (available from early 2020)	○	○	○
Doors – Dual side load doors, glazed driver and passenger's side, fixed	○	○	○
Side windows, Double Cab-in-Van – Second row, fixed	○	–	–
Side windows, Double Cab-in-Van – Second row, sliding	●	●	●
Engine undershield	○	○	○
Carpet and trim			
Floor covering – Cab, easy-clean rubber	●	●	●
Headlining – Cab, moulded	●	●	●
Certification			
Vehicle Identification Number – Visible	●	●	●
Exterior functional			
Mudflaps – Front	○	○	○
Mudflaps – Rear	●	●	●
Tow bar with Trailer Sway Control and 13-pin electrics (tachograph may be required) (not available on L4 350 Double Cab-in-Van)	○	○	○
Rear window ladder (only available with 180° hinged rear doors) (not available with L4 models)	○	○	○
Load compartment			
Bulkhead – Polymer moulded, unglazed (Van only)	○	○	○
Bulkhead – Polymer moulded with window (Van only)	○	○	○
Bulkhead – Full-width metal, unglazed (Van only)	●	●	●
Bulkhead – Polymer moulded with window (Double Cab-in-Van only)	●	●	●
Complete rear sidewall trim half-height board with wheel arch covers (optional on Van)	○	○	○
Complete rear trim full-height board with wheel arch covers (Van only)	○	●	●
Easy Clean Load Floor (Van only, not available with power side step)	○	●	●
Less Easy Clean Load Floor (Van only)	●	○	○
Load compartment – DIN 75410 compliant tie-down loops	●	●	●
Multi-functional loadfloor (L3 models only, Van only)	○	○	○
Cargo area management system 1 (Van only)	○	○	○
Instruments and controls			
Gearshift Indicator light	●	●	●

● = Standard, ○ = Option, at extra cost, □ = Part of an option pack, at extra cost.

Special Vehicle Options

	SVO Code	Leader	Trend	Limited
Body				
Omit passenger seat (no pedestal) (not available on Double Cab-in-Van)	A304	○	-	-
250 degree rear unglazed cargo doors (contains passenger's side load (sliding) door)not available with dual side sliding load doors, Van only)	H250	○	○	○
Parking distance sensor(s) – Front and rear, configurable (includes front fog lights)	A095	○	○	-
Seat Pack 3 – Orange seat belts – Single Passenger Seat · 8 way driver seat (fore/aft, recline, up/down, tilt) with armrest · 4 way single passenger seat (fore/aft, recline)	A305	○	-	-
Seat Pack 4 – Orange seat belts – Dual Passenger Seat · 8 way driver seat (fore/aft, recline, up/down, tilt) with armrest · Fixed dual passenger seat	A306	○	-	-
Seat Pack 5 – Orange seat belts – Delete Passenger Seat · 8 way driver seat (fore/aft, recline, up/down, tilt) with armrest (Van only)	A307	○	-	-
Electrical				
DPF manual regeneration	A660	○	○	-
Engine rpm speed control, 1300-3000 rpm (not available with automatic transmission)	A003	○	○	-
Single AGM deep cycle battery H8 95Ah (available as an option pack on Van)	A739	○	○	-
Auxiliary fuse panel	A526	○	○	○
Beacon Preparation Pack – Switch and front and rear wiring (includes auxiliary fuse panel (A526)) (cannot be ordered with rear air conditioning) (available as an option pack on Van)	A606	○/□	○/□	-
High Specification Interface Connector – Provides a range of hardwired signals and power for converters (includes auxiliary fuse panel (A526))	A608	○/□	○/□	-
Power Equipment Group 5 (Rear Air Conditioning)				
FWD Van only	A813	○	○	○
Trailer tow electrics (connector and wiring) without the tow bar (L2 (MWB) and L3 (LWB) Van only)				
	A055	○	○	○
The Ford Programmable Battery Guard – Patented 10-mode programmable battery guard system capable of protecting Ford and 3rd party battery rpm speed control and the Ford Programmable Battery Guard (not available with automatic transmissions)				
	A540	○/□	○/□	-
Converter – High-Power Supply System – Meets heavy power-take-off requirements by equipping vehicles with two high-performance deep cycle AGM batteries (2 x 95 Ah), 240A alternator, engine				
	A550	○	○	- ⊕
Paint				
Special Paint, 134 colours available, consult Dealer for details*	Various	○	○	○

○ = Option, at extra cost.

*SVO paint suffix must be entered at time of ordering. SVO paint pulls self-colour (black) bumpers, bodyside mouldings, mirror housings and door handles.

Model availability

	290 L2 H2	310 L2 H2	310 L2 H3	310 L3 H2	310 L3 H3	330 L2 H2	330 L2 H3	330 L3 H2	330 L3 H3	350 L2 H2	350 L2 H3	350 L3 H2	350 L3 H3	350 L4 H3	470 L4 H3
Van															
FWD															
2.0 TDCi Ford EcoBlue 105 PS (77 kW)	●	●	●	●	●	●	●	●	●	●	●	●	●	-	-
2.0 TDCi Ford EcoBlue 130 PS (96 kW)	●	●	●	●	●	●	●	●	●	●	●	●	●	-	-
2.0 TDCi Ford EcoBlue 130 PS (96 kW) 6-speed automatic	-	●	●	-	-	-	-	-	-	●	●	●	●	-	-
2.0 TDCi Ford EcoBlue 170 PS (125 kW)	-	-	-	-	-	-	-	-	-	●	●	●	●	-	-
2.0 TDCi Ford EcoBlue 170 PS (125 kW) 6-speed automatic	-	●	●	-	-	-	-	-	-	●	●	●	●	-	-
2.0 TDCi Ford EcoBlue 185 PS (136 kW)	-	-	-	-	-	-	-	-	-	-	-	●	●	-	-
2.0 TDCi Ford EcoBlue 185 PS (136 kW) 6-speed automatic	-	-	-	-	-	-	-	-	-	●	●	●	●	-	-
2.0L Ford EcoBlue 130PS FWD EcoBlue Hybrid	-	-	-	-	-	-	-	-	-	●	●	●	●	-	-
RWD															
2.0 TDCi Ford EcoBlue 105 PS (77 kW)	-	-	-	-	-	-	-	-	-	●	●	●	●	●	-
2.0 TDCi Ford EcoBlue 130 PS (96 kW)	-	-	-	-	-	-	-	-	-	●	●	●	●	●	●
2.0 TDCi Ford EcoBlue 170 PS (125 kW)	-	-	-	-	-	-	-	-	-	●	●	●	●	●	●
2.0 TDCi Ford EcoBlue 185 PS (136 kW)	-	-	-	-	-	-	-	-	-	●	●	●	●	-	-
AWD															
2.0 TDCi Ford EcoBlue 130 PS (96 kW)	-	-	-	-	-	-	-	-	-	●	●	●	●	-	-
2.0 TDCi Ford EcoBlue 170 PS (125 kW)	-	-	-	-	-	-	-	-	-	●	●	●	●	-	-
Double Cab-in-Van															
FWD															
2.0 TDCi Ford EcoBlue 130 PS (96 kW)	-	-	-	-	-	-	-	-	-	●	●	●	●	-	-
2.0 TDCi Ford EcoBlue 130 PS (96 kW) 6-speed automatic	-	-	-	-	-	-	-	-	-	-	-	●	●	-	-
2.0 TDCi Ford EcoBlue 170 PS (125 kW)	-	-	-	-	-	-	-	-	-	-	-	●	●	-	-
2.0 TDCi Ford EcoBlue 170 PS (125 kW) 6-speed automatic	-	-	-	-	-	-	-	-	-	-	-	●	●	-	-
2.0 TDCi Ford EcoBlue 185 PS (136 kW)	-	-	-	-	-	-	-	-	-	-	-	●	●	-	-
2.0 TDCi Ford EcoBlue 185 PS (136 kW) 6-speed automatic	-	-	-	-	-	-	-	-	-	-	-	●	●	-	-
2.0L Ford EcoBlue 130PS FWD EcoBlue Hybrid	-	-	-	-	-	-	-	-	-	●	●	●	●	-	-
RWD															
2.0 TDCi Ford EcoBlue 130 PS (96 kW)	-	-	-	-	-	-	-	-	-	●	●	●	●	●	-
2.0 TDCi Ford EcoBlue 170 PS (125 kW)	-	-	-	-	-	-	-	-	-	●	●	●	●	-	-
2.0 TDCi Ford EcoBlue 185 PS (136 kW)	-	-	-	-	-	-	-	-	-	-	-	●	●	-	-
2.0L Ford EcoBlue 130PS RWD EcoBlue Hybrid	-	-	-	-	-	-	-	-	-	-	-	●	●	-	-
AWD															
2.0 TDCi Ford EcoBlue 130 PS (96 kW)	-	-	-	-	-	-	-	-	-	●	●	●	●	-	-

● = Available, - = Not available. **L2** = Medium wheelbase, **L3** = Long wheelbase, **L4** = Long wheelbase extended length, **H2** = Medium Roof, **H3** = High Roof, **FWD** = Front-wheel drive, **RWD** = Rear-wheel drive, **AWD** = All-wheel drive. All engines are EU6.2 with 6-speed manual transmission unless stated.

Styling and appearance

	Leader	Trend	Limited
Wheels			
Steel – 15"x6½" (fitted with 215/65 R15 BSW tyres)* (standard on 290 and 310 series only and not available when specified with automatic transmission)	●	●	–
Steel – 16"x6½" (fitted with 235/65 R16C BSW tyres)* (290 and 310 series with automatic transmission: 215/65 R16C tyres) (standard on 330 and 350 models only, and on 290 and 310 series when specified with automatic transmission)	●	●	–
Steel – 16"x 6.0", dual rear wheels, hub caps on front wheels (fitted with 195/75 R16 BSW tyres)* (standard on L4 350HD and 470 models only)	●	●	–
Alloy – 16"x6½", 5-spoke (fitted with 215/65 R16C BSW tyres)* (not available on L4) (290 and 310 series: 215/65 R16C BSW tyres; 330 and 350 series: 235/65 R16C BSW tyres) (includes locking wheel nuts)	–	○	●
Wheel covers – Half caps	●	–	–
Wheel covers – Full	–	●	–
Locking wheel nuts	–	□	●
Spare – Full-size steel (standard on L4 350HD and 470 models)	○	○	○
Tyre inflator kit	●	●	●
Design features			
Body – H2 (Medium Roof) (not available on L4 models)	●	●	●
Body – H3 (High Roof) (standard on L4 models, and not available on L2 290 variants)	○	○	○
Door mirrors – Blind spot eliminator and integrated side indicator	●	●	●
Door mirrors – Manual adjust	●	–	–
Door mirrors – Electrically-operated and heated	○/□	–	–
Door mirrors – Power-foldable, electrically-operated and heated	○/□	●	●
Bodyside mouldings – Wide, self colour	●	●	●
Front bumper – Self colour	●	●	–
Front bumper – Body colour upper, self colour lower	–	–	●
Rear bumper – Self colour with integrated step	●	●	●
Door handles – Self colour	●	●	●
Cargo door handle – Self colour	●	●	●
Front grille – Self colour	●	–	–
Front grille – Self colour with chrome surround	–	●	●
Tinted glass	●	●	●
Option Packs			
Low Visibility Pack – Quickclear heated windscreen, low washer fluid sensor and electrically-operated and heated door mirrors	○	–	–
Premium Visibility Pack – includes Lane-Keeping Aid, Rear View Camera	–	○	○

● = Standard, ○ = Option, at extra cost, □ = Part of an option pack, at extra cost. *The wheel you choose will be fitted with the tyre size noted, but no choice of tyre brand is available.

Max. GTM (kg)

	Axle ratio ⁰⁰		GVM					
			290	310	330	350	350HD	470
Van/Double Cab-in-Van								
FWD								
2.0 TDCi Ford EcoBlue 105 PS (77 kW)	4.429/3.263	●	4940	4940	5065	5065	-	-
2.0 TDCi Ford EcoBlue 130 PS (96 kW)	4.429/3.263	●	5140	5140	5065	5065	-	-
2.0 TDCi Ford EcoBlue 130 PS (96 kW)	4.93/3.450	○	-	-	5700	5700	-	-
2.0 TDCi Ford EcoBlue 130 PS (96 kW) 6-speed automatic	3.39	●	-	4140	-	4250	-	-
2.0 TDCi Ford EcoBlue 130 PS (96 kW) Hybrid	4.43/4.93	●/○	-	-	-	5065/5700	-	-
2.0 TDCi Ford EcoBlue 170 PS (125 kW)	4.429/3.263	●	-	-	-	5065	-	-
2.0 TDCi Ford EcoBlue 170 PS (125 kW)	4.71**/4.93	●	-	-	-	6000	-	-
2.0 TDCi Ford EcoBlue 170 PS (125 kW)	4.93/3.450	○	-	-	-	6000	-	-
2.0 TDCi Ford EcoBlue 170 PS (125 kW) 6-speed automatic	3.39	●	-	4140	-	4250	-	-
2.0 TDCi Ford EcoBlue 185 PS (136 kW)	4.429/3.263	●	-	-	-	5065	-	-
2.0 TDCi Ford EcoBlue 185 PS (136 kW)	4.93/3.450	○	-	-	-	6000	-	-
2.0 TDCi Ford EcoBlue 185 PS (136 kW) 6-speed automatic	3.39	●	-	-	-	4250	-	-
RWD								
2.0 TDCi Ford EcoBlue 105 PS (77 kW)	3.73	●	-	-	-	5600	-	-
2.0 TDCi Ford EcoBlue 130 PS (96 kW)	3.31	●	-	-	-	5500	-	-
2.0 TDCi Ford EcoBlue 130 PS (96 kW)	3.73	○	-	-	-	6100	-	-
2.0 TDCi Ford EcoBlue 130 PS (96 kW)	4.10	●	-	-	-	6500	6500	6500
2.0 TDCi Ford EcoBlue 130 PS (96 kW) Hybrid	3.31/3.73	●/○	-	-	-	5500/6100	-	-
2.0 TDCi Ford EcoBlue 170 PS (125 kW)	3.31	●	-	-	-	5650	-	-
2.0 TDCi Ford EcoBlue 170 PS (125 kW)	3.73	○	-	-	-	6400	-	-
2.0 TDCi Ford EcoBlue 170 PS (125 kW)	4.10	●	-	-	-	7000	7000	7000
2.0 TDCi Ford EcoBlue 185 PS (136 kW)	3.31	●	-	-	-	5650	-	-
2.0 TDCi Ford EcoBlue 185 PS (136 kW)	3.73	○	-	-	-	6400	-	-
2.0 TDCi Ford EcoBlue 185 PS (136 kW)	4.10	○	-	-	-	7000	-	-
AWD								
2.0 TDCi Ford EcoBlue 130 PS (96 kW)	4.10	●	-	-	-	6000	-	-
2.0 TDCi Ford EcoBlue 170 PS (125 kW)	4.10	●	-	-	-	6000	-	-

● = Standard, ○ = Option. **Note:** All engines are EU6.2 unless stated. ⁰⁰The illustrated axle ratio shown is the one available dependent upon model, GVM payload and engine combination. *GTM is limited to 5,500 kg if fitted with rear air conditioning. Consult your Dealer for more information.

Max. braked trailer plate (kg)

	Axle ratio ⁹⁹		GVM					
			290	310	330	350	350HD	470
Van/Double Cab-in-Van								
FWD								
2.0 TDCi Ford EcoBlue 105 PS (77 kW)	4.429	●	2450/-	2450/-	2500/-	2500/-	-/-	-/-
2.0 TDCi Ford EcoBlue 130 PS (96 kW)	4.429	●	2550/-	2550/-	2550/-	2500/2500	-/-	-/-
2.0 TDCi Ford EcoBlue 130 PS (96 kW)	4.93	○	-/-	-/-	2800/-	2800/2800	-/-	-/-
2.0 TDCi Ford EcoBlue 130 PS (96 kW) 6-speed automatic	3.39	●	-/-	1750-1800/-	-/-	1800-1900/ 1650-1700	-/-	-/-
2.0 TDCi Ford EcoBlue 130 PS (96 kW) Hybrid	4.43/4.93		-/-	-/-	-/-	2500 / 2800	-/-	-/-
2.0 TDCi Ford EcoBlue 170 PS (125 kW)	4.18	●	-/-	-/-	-/-	-/-	-/-	-/-
2.0 TDCi Ford EcoBlue 170 PS (125 kW)	4.429	●	-/-	-/-	-/-	2500/2500	-/-	-/-
2.0 TDCi Ford EcoBlue 170 PS (125 kW)	4.71	●	-/-	-/-	-/-	-/-	-/-	-/-
2.0 TDCi Ford EcoBlue 170 PS (125 kW)	4.93	○	-/-	-/-	-/-	2800/2800	-/-	-/-
2.0 TDCi Ford EcoBlue 170 PS (125 kW) 6-speed automatic	3.39	●	-/-	1750/-	-/-	1800-1850/1700	-/-	-/-
2.0 TDCi Ford EcoBlue 185 PS (136 kW)	4.429	●	-/-	-/-	-/-	2500/2500	-/-	-/-
2.0 TDCi Ford EcoBlue 185 PS (136 kW)	4.93	○	-/-	-/-	-/-	2800/2800	-/-	-/-
2.0 TDCi Ford EcoBlue 185 PS (136 kW) 6-speed automatic	3.39	●	-/-	-/-	-/-	1800-1850/-	-/-	-/-
RWD								
2.0 TDCi Ford EcoBlue 105 PS (77 kW)	3.31	○	-/-	-/-	-/-	2550/-	-/-	-/-
2.0 TDCi Ford EcoBlue 105 PS (77 kW)	3.73	●	-/-	-/-	-/-	2800/-	-/-	-/-
2.0 TDCi Ford EcoBlue 130 PS (96 kW)	3.31	●	-/-	-/-	-/-	2750/2750	-/-	-/-
2.0 TDCi Ford EcoBlue 130 PS (96 kW)	3.73	○	-/-	-/-	-/-	2800/2800	-/-	-/-
2.0 TDCi Ford EcoBlue 130 PS (96 kW)	4.10	○	-/-	-/-	-/-	3000/3000	3000/-	2300/-
2.0 TDCi Ford EcoBlue 130 PS (96 kW) Hybrid	3.31/3.73		-/-	-/-	-/-	2750/2800	-/-	-/-
2.0 TDCi Ford EcoBlue 170 PS (125 kW)	3.31	●	-/-	-/-	-/-	2800/2800	-/-	-/-
2.0 TDCi Ford EcoBlue 170 PS (125 kW)	3.73	○	-/-	-/-	-/-	2900/2900	-/-	-/-
2.0 TDCi Ford EcoBlue 170 PS (125 kW)	4.10	●	-/-	-/-	-/-	3500/3500	3500/-	3500/-
2.0 TDCi Ford EcoBlue 185 PS (136 kW)	3.31	●	-/-	-/-	-/-	2800/2800	-/-	-/-
2.0 TDCi Ford EcoBlue 185 PS (136 kW)	3.73	○	-/-	-/-	-/-	2900/2900	-/-	-/-
2.0 TDCi Ford EcoBlue 185 PS (136 kW)	4.10	○	-/-	-/-	-/-	3500/3500	-/-	-/-
AWD								
2.0 TDCi Ford EcoBlue 130 PS (96 kW)	4.10	●	-/-	-/-	-/-	2800/2800	-/-	-/-
2.0 TDCi Ford EcoBlue 170 PS (125 kW)	4.10	●	-/-	-/-	-/-	2800/2800	-/-	-/-

● = Standard, ○ = Option, at extra cost. **Note:** All engines are EU6.2 unless stated. ⁹⁹The illustrated axle ratio shown is the one available dependent upon model, GVM payload and engine combination. *GTM is limited to 5,500 kg if fitted with rear air conditioning. **Vehicles fitted with optional rear air suspension are not suitable for towing and therefore have no trailer plate value. Maximum unbraked trailer mass is 750 kg. **Available from February 2020 production.

Fuel economy and CO₂ emissions (EU6.2)

The fuel economy figures quoted in the table below are achieved by following strict EU governed test procedures and are specifically designed to enable customers to compare vehicles from all manufacturers on a like-for-like basis. Fuel consumption is directly affected by the length of the journey; number of passengers and amount of luggage carried; individual driving style; road and traffic conditions; weather conditions; vehicle age, mileage, condition and standard of maintenance; use of vehicle features such as air conditioning; and any modifications to the vehicle such as the addition of a roof rack. Your fuel economy will vary based on these and other factors and, for these reasons, many drivers may not achieve the EU fuel economy figures (below) in day-to-day driving, although the vehicle is technically capable of doing so.

	Axle ratio ⁰⁰⁰	CO ₂ emissions (g/km) ⁰⁰⁰	Fuel consumption in L/100km ⁰⁰⁰			Fuel consumption in MPG ⁰⁰⁰		
			Urban	Extra Urban	Combined	Urban	Extra Urban	Combined
Van/Double Cab-in-Van FWD								
2.0 TDCi Ford EcoBlue 105 PS (77 kW)	4.429/3.263	170-181	7.0-7.3	6.2-6.6	6.5-6.9	38.7-40.4	42.8-45.6	40.9-43.5
2.0 TDCi Ford EcoBlue 130 PS (96 kW)	4.429/3.263	170-179	7.0-7.2	6.2-6.6	6.5-6.8	39.2-40.4	42.8-45.6	41.5-43.5
2.0 TDCi Ford EcoBlue Hybrid 130 PS (96 kW) mHEV	4.429/3.263	158-165	6.2-6.3	6.0-6.4	6.0-6.3	44.8-45.6	44.1-47.1	44.8-47.1
2.0 TDCi Ford EcoBlue 130 PS (96 kW)	4.93/3.450	174-179	7.3-7.5	6.2-6.4	6.6-6.8	37.7-38.7	44.1-45.6	41.5-42.8
2.0 TDCi Ford EcoBlue 130 PS (96 kW) 6-speed automatic	3.39	177-182	7.4	6.5-6.7	6.7-6.9	38.2	42.2-43.5	40.9-42.2
2.0 TDCi Ford EcoBlue 170 PS (125 kW)	4.429/3.263	172-179	7.0-7.2	6.3-6.6	6.5-6.8	39.2-40.4	42.8-44.8	41.5-43.5
2.0 TDCi Ford EcoBlue Hybrid 170 PS (125 kW) mHEV	4.429/3.263	158-165	6.2	6.0-6.4	6.0-6.3	45.6	44.1-47.1	44.8-47.1
2.0 TDCi Ford EcoBlue 170 PS (125 kW)	4.93/3.450	174-179	7.3-7.5	6.2-6.4	6.6-6.8	37.7-38.7	44.1-45.6	41.5-42.8
2.0 TDCi Ford EcoBlue 170 PS (125 kW) 6-speed automatic	3.39	177-182	7.4	6.5-6.7	6.7-6.9	38.2	42.2-43.5	40.9-42.2
2.0 TDCi Ford EcoBlue 185 PS (136 kW)	4.429/3.263	172-179	7.0-7.2	6.3-6.6	6.5-6.8	39.2-40.4	42.8-44.8	41.5-43.5
2.0 TDCi Ford EcoBlue 185 PS (136 kW)	4.93/3.450	174-179	7.3-7.5	6.2-6.4	6.6-6.8	37.7-38.7	44.1-45.6	41.5-42.8
2.0 TDCi Ford EcoBlue 185 PS (136 kW) 6-speed automatic	3.39	177-182	7.4	6.5-6.7	6.7-6.9	38.2	42.2-43.5	40.9-42.2